



518 REACH



- **5,500 LBS. CAPACITY**
- **18 FEET 4 INCHES OF LIFT HEIGHT**
- **COMPACT, MANEUVERABLE DESIGN**
- **EXCELLENT OPERATOR VISIBILITY**
- **ROOMY, COMFORTABLE OPERATORS MODULE**
- **ERGONOMIC CONTROLS**
- **FULL RANGE OF ATTACHMENTS AVAILABLE**
- **NORTH AMERICAN MANUFACTURED**



LOAD LIFTER FEATURES DO WORK FOR YOU

PERFORMANCE

Rated Capacity	5,500 lb	2,495 kg
Maximum Lift Height	18 ft 4 in.	5.6 m
Load at Max Height	4,400 lb	1,996 kg
Maximum Forward Reach	10 ft 11 in.	3.3 m
Load at Max Reach	1,850 lb	839 kg
Lift Speed (boom retracted)		
Up	6.8 sec	
Down	4.6 sec	
Boom Speed (extended/retracted)		
Extended	6.7 sec	
Retracted	3.8 sec	
Top Travel Speed (4-Speed)	15 mph	24 kph
Drawbar Pull (loaded)	8,700 lb	3,946 kg
Outside Turning Radius	127 in.	3.2 m
Operating Weight	11,000 lb	4,990 kg

STANDARD SPECIFICATIONS

Engine

Make and Model	Deutz TD 2.9 L L4	
No. of Cylinders	4	
Displacement	177 cu in.	2.9 L
Gross Power Basic	74 hp	55 kW
Maximum Torque @ 1800 rpm	192 lb-ft	260 Nm
Fuel Tank Capacity	24 gal	91 L

Transmission

- Hydrostatic

Axles

- High bias limited slip differential on front axle.
- Planetary on front and rear axles.

Brakes

- Service brakes are inboard wet disc brake on front axle.
- Parking brakes are wet disc spring-applied hydraulic release.

Tires

- Standard 12 × 16.5 Pneumatic
- Optional 12 × 16.5 Foam-Filled
- 14 × 17.5 Foam-Filled
- 14 × 17.5 Pneumatic
- 33 × 12 Solid

Cab

- Certified ROPS/FOPS structure
- Adjustable suspension seat
- Horn

Steering 4-Wheel

- Operator selectable 4-wheel circle, 4-wheel crab, 2-wheel front.

Instruments

- Hourmeter
- Steering mode
- Engine coolant temperature
- Fuel gauge
- Alternator gauge
- Parking brake indicator
- Travel speed
- Engine speed
- Vehicle and engine system indicators, including fault codes

Hydraulic System-Implement

- Capacity 24 gal 91 L
- Single-section gear pump.
- Auxiliary hydraulics used for all attachments equipped with cylinders or other hydraulic components.

Dimensions



Load Chart and Dimensions

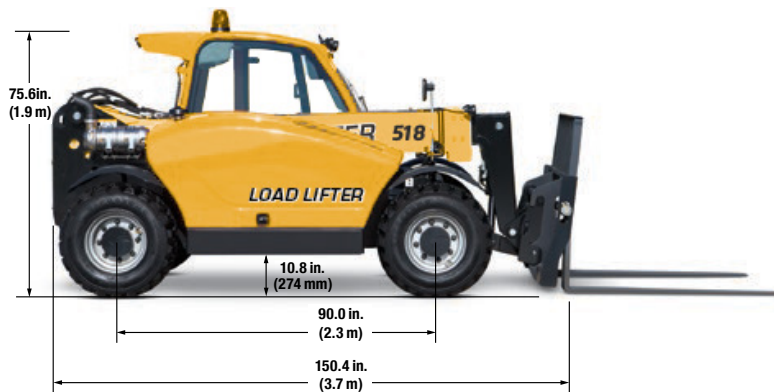
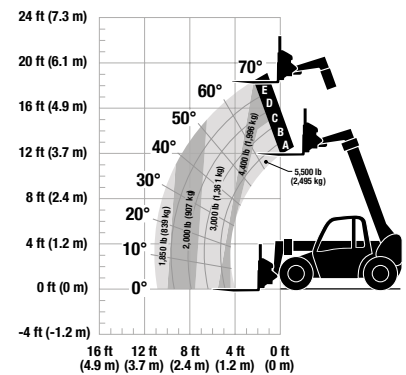

ACCESSORIES & OPTIONS

- Enclosed Cab
- Battery Disconnect Switch
- Road Light Package
- Work Light Package
- Skylight/Rear Wiper Package
- Radio Ready Kit (Enclosed Cab Only)
- Tow Hitch w/trailer plug
- Tow Hitch w/automatic pin & trailer plug
- Molded Floor Mat
- Fenders
- Brick Guard
- Air Conditioning
- Block Heater
- Tilt Steering
- Hydraulic Quick Switch
- Rear Auxiliary Hydraulics
- Universal Skid Steer Coupler
- Boom brushes
- Reversing fan
- Pre-cleaner

ATTACHMENTS

Standard Carriage	50 in. 1.3 m	
Side-Tilt Carriage	48 in. 1.2 m	
Pallet Forks	2 in. × 4 in. × 48 in.	51 mm × 102 mm × 1.2 m
Lumber Forks	1.5 in. × 6 in. × 60 in.	38 mm × 152 mm × 1.5 m
Cubing Forks	2 in. × 2 in. × 48 in.	51 mm × 51 mm × 1.2 m
General Purpose Bucket	73 in., 1.0 cu yd	1.85 m, 0.76 m ³
Light Material Bucket	72 in., 1.7 cu yd	1.8 m, 1.29 m ³
Grapple Bucket	72 in., 1.0 cu yd	1.8 m, 0.76 m ³
Lifting Hook		



This information contained herein is general in nature and not intended for specific application purpose. Load Lifter reserves the right to make changes in specifications, make improvements, or discontinue manufacture at any time without notice or obligation.

LOAD LIFTER MANUFACTURING LTD.
 3 Anderson Boulevard, Stouffville, Ontario, Canada, L4A 7X4
 Tel. 905-642-9756, Fax. 905-640-1437 www.load-liftermfg.com, info@load-liftermfg.com