



2200-2400 G SERIES



- 15,000 LBS CAPACITY
- HEAVY DUTY C-THRU ROLLER MASTS
- OIL IMMERSED DISC BRAKES
- TURBO CHARGED ENGINE
- FULL POWERSHIFT TRANSMISSION
- HIGH VISIBILITY OPERATORS COMPARTMENT
- ERGONOMIC CONTROLS
- EASY OFF AND ON ACCESS
- AVAILABLE FOUR WHEEL DRIVE
- FULL RANGE OF ATTACHMENTS



*Model
2414-15G
complete with
Two Stage Pipe Clamp*

LOAD LIFTER FEATURES DO WORK FOR YOU

MACHINE APROX. WEIGHTS

15K 11,249 kg (24,800 lbs.)

MACHINE DIMENSIONS

A (Tilt Back) 14°
 B (Tilt Forward) 24°
 C (Machine Ground Clearance) 15"
 D (Mast Ground Clearance) 12"
 E (Counterweight Overhang) 42"-15K
 F (Wheelbase) 94 1/2"-15K
 G (C/L Drive Axle to Face of Forks) 37 1/2"
 H (Overall Length to Face of Forks) 174"
 I (Overall Height Top of Canopy) 97"
 J (Turning Clearance) 4WD 198"
 K (Turning Radius) 4WD 192"
 L (Overall Width) 91"

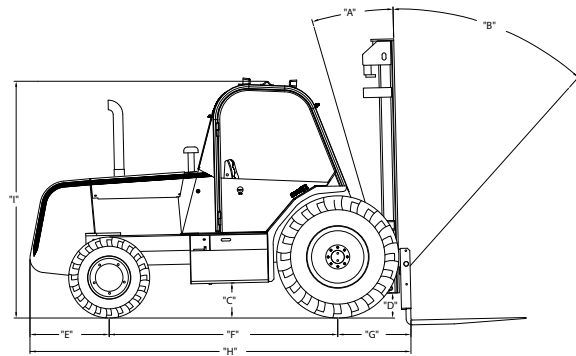
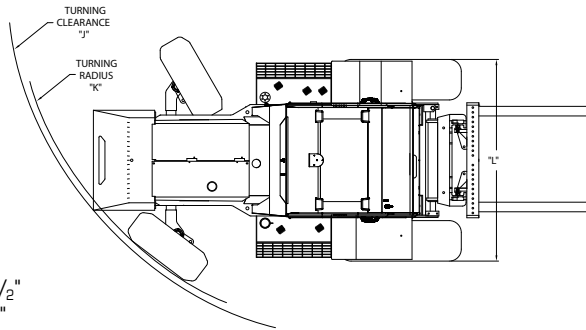

ENGINE

Make	FPT F34
Displacement	3.4 Litres (207.5 cu. in.)
Gross H.P.	74.3 H.P. (55 KW.)
Maximum Torque	291 NM. @ 1600 RPM (214.6 lb-ft)
Rated Speed	2500 RPM.

TRANSMISSION

Type	4 Speed Full Powershift c/w "Smartshift Feature"
Speeds	1st 3.8 km (2.3 mph) 2nd 6.7 km (4.2 mph) 3rd 12.3 km (7.6 mph) 4th 21.8 km (13.5 mph)

HYDRAULIC SYSTEM

Pump	Gear Type System c/w Load Sense Steering Circuit
Filter	25 Micron Replaceable Element
Modular Control Valve	c/w Tilt Lock System

ELECTRICAL SYSTEM

Volts	12
Alternator	85 Amp.
Instrumentation	Full LED Display

STANDARD EQUIPMENT

- 6" Mast Side Shift
- 4 Speed "SmartShift" Full Powershift Transmission
- Electric Column Shift
- Tilt & Telescopic Steering Console
- Hydrostatic Load Sense Power Steering
- Safety Start
- Dry Type Air Cleaner
- Retractable Seat Belt
- Height Adjustable Seat
- Digital Touch Screen Display
- Overhead F.O.P.S. Canopy
- Circuit Breakers
- Block Heater
- Manifold Heater
- Heavy Duty Battery
- Anti Freeze -40
- Horn
- Four Work Lights
- Transmission De Clutch
- 14 foot C-Thru Mast
- 60" Shaft Carriage
- 48" Pallet Forks

FLUID CAPACITIES

Cooling System	11.5 litres / 12.2 Quarts
Engine Oil	6.8 litres / 7.2 Quarts
Fuel	100 litres / 26.4 U.S. Gal.
Hydraulic Oil	85 litres / 22.5 U.S. Gal.
Transmission Oil	21.4 litres / 22.2 Quarts

BRAKES

Service Parking	Full Power Multiple Wet Disc
	Manual External Disc on Transmission

AXLES

Drive	Heavy Duty Inboard Planetary Drive
Steer 2 WD	Large 8" x 4" Solid Beam c/w Oversize Center Steer Control and Track Rod Design, Large Tapered Roller Bearing Spindle Wheel Ends High Strength Cast Steel Housing c/w Planetary Drive Wheel Ends and 50° Lock Angle
Steer 4 WD	

TIRES

Drive - 15K		15.5R x 25 Radial
Steer	2WD	10.00 x 20 16 ply
	4WD	15 x 19.5 14 ply

OPTIONAL EQUIPMENT

- All Steel Ergonomic Cab Assembly
- R.O.P.S. Cab Assembly
- Mirrors
- Air Conditioning
- Suspension Seat
- Air Ride Seat
- Cold Weather Package
- Vandalism Package
- Exhaust Purifier
- High Air Intake
- Cyclonic Pre-Cleaner
- Lift Circuit Cushion Accumulator
- Range of Fork Positioners
- Load Grapples
- Hydraulic Bucket
- Utility Blades
- Full Range of Attachments



This information contained herein is general in nature and not intended for specific application purpose. Load Lifter reserves the right to make changes in specifications, make improvements, or discontinue manufacture at any time without notice or obligation.

LOAD LIFTER MANUFACTURING LTD.
 3 Anderson Blvd., Uxbridge, Ontario, Canada, L9P 0G5
 Tel. 905-642-9756, Fax. 905-640-1437, www.load-liftermfg.com, info@load-liftermfg.com