



AGRI-LIFTER G SERIES



- 4-5,000 LB. CAPACITY
- OIL IMMERSED MULTIPLE WET DISC BRAKES
- HEAVY DUTY STEER AXLE
- AVAILABLE C-THRU ROLLER MASTS
- COMPONENTIZED POWER TRAIN
- ROOMY OPERATORS COMPARTMENT
- AVAILABLE ERGONOMIC CAB ASSEMBLY
- EASY ON AND OFF ACCESS
- HIGH GROUND CLEARANCE
- LOW GROUND PRESSURE
- FULL RANGE OF FLOTATION TIRES
- AVAILABLE FOUR WHEEL DRIVE
- AVAILABLE BIG ROLL CARRIAGE
- FUEL EFFICIENT EPA COMPLIANT DIESEL ENGINE

DESIGNED AND BUILT FOR TODAY'S SOD GROWER.

MACHINE APROX. WEIGHTS

4,000 lb - 4808 kg (10,600 lbs)
5,000 lb - 5058 kg (11,150 lbs)

MACHINE DIMENSIONS

A (Tilt Back) 14"
B (Tilt Forward) 24"
C (Machine Ground Clearance) 15"
D (Mast Ground Clearance) 12"
E (Counterweight Overhang) 25³/₄"
F (Wheelbase) 83"
G (C/L Drive Axle to Face of Forks) 34³/₁₆"
H (Overall Length to Face of Forks) 143"
I (Overall Height Top of Canopy) 97"
J (Turning Clearance) 2WD 168", 4WD 179"
K (Turning Radius) 2WD 164", 4WD 175"
L (Overall Width) 84"

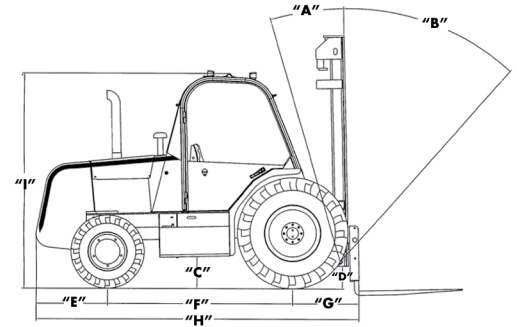
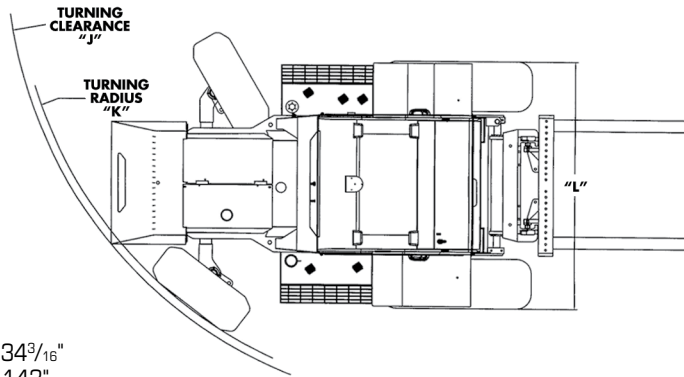

ENGINE

Make FPT F34
Displacement 3.4 Litres (207.5 cu. in.)
Gross H.P. 74.3 H.P. (55 KW.)
Maximum Torque 291 NM. @ 1600 RPM (214.6 lb-ft)
Rated Speed 2500 RPM.

FLUID CAPACITIES

Cooling System	11.5 litres / 12.2 Quarts
Engine Oil	6.8 litres / 7.2 Quarts
Fuel	100 litres / 26.4 U.S. Gal.
Hydraulic Oil	85 litres / 22.5 U.S. Gal.
Transmission Oil	21.4 litres / 22.2 Quarts

TRANSMISSION

Type 4 Speed Synchromesh with Power Reverser & Torque Converter
Speeds
1 4.6 km (2.9 mph)
2 9.6 km (6.0 mph)
3 17.6 km (11 mph)
4 29.6 km (19 mph)

AXLES

Drive Heavy Duty Outboard Planetary Drive
Steer 2 WD Large 5" x 3" Solid Beam c/w Large Tapered Roller Bearing Spindle Wheel Ends
Steer 4 WD High Strength Cast Steel Housing c/w Planetary Drive Wheel Ends and 50° Lock Angle

HYDRAULIC SYSTEM

Pump Gear Type System c/w Load Sense Steering Circuit
Filter 25 Micron Replaceable Element
Modular Control Valve c/w Tilt Lock System

TIRES

Drive	2WD & 4WD	16.9 x 24 - 12 ply lug
Steer	2WD	11:00 x 16 12 ply
	4WD	14 x 17.5 14 ply lug

ELECTRICAL SYSTEM

Volts 12
Alternator 100 Amp.
Instrumentation Full LED Display

STANDARD EQUIPMENT

- 6" Mast Side Shift
- 4 Speed Synchromesh Transmission
- Power Reverser
- Electric Column Shift
- Tilt & Telescopic Steering Console
- Hydrostatic Power Load Sense Steering
- Safety Start
- Dry Type Air Cleaner
- Digital Touch Screen Display
- Retractable Seat Belts
- Height Adjustable Seat
- Overhead F.O.P.S. Canopy
- Circuit Breakers
- Block Heater
- Manifold Heater
- Heavy Duty Battery
- Anti Freeze -40
- Horn
- Four Work Lights
- Transmission De Clutch
- 14 foot C-Thru Mast
- 48" Shaft Carriage
- 1 1/2 x 4 x 48" Shaft Forks

OPTIONAL EQUIPMENT

- "Smart Shift" Full Powershift Transmission
- Independent Brake Pedals
- All Steel Ergonomic Cab Assembly
- Mirrors
- Air Conditioning
- Suspension Seat
- Cold Weather Package
- Vandalism Package
- Murphy Shutdown System
- Rear Tire Fenders
- Full Width Front Fenders
- Wide Range of Flotation Tires
- High Air Intake
- Cyclonic Pre-Cleaner
- Power Brakes
- Lift Circuit Cushion Accumulator
- Fork Positioner
- Load Clamp
- Hydraulic Bucket
- Full Range of Attachments
- Big Roll Carriage

This information contained herein is general in nature and not intended for specific application purpose. Load Lifter reserves the right to make changes in specifications, make improvements, or discontinue manufacture at any time without notice or obligation.



LOAD LIFTER MANUFACTURING LTD.

3 Anderson Boulevard, Uxbridge, Ontario, Canada, L9P 0G5

Tel. 905-642-9756, Fax. 905-640-1437 www.load-liftermfg.com, info@load-liftermfg.com